

Core Cool

MISTING SYSTEM

INCLUDED IN CORE COOL PACKAGE

25" Core Cool Fan Assembly EC	X1
25" Core Cool Air Shaper.....	X1
Post Mount Bracket for 25" CC.....	X1
Core Cool Quad Tip Nozzle Assembly.....	X3
Ultra Fine Nozzle Tips	X24
Block Off Tips (not typically required).....	X2
PE Pipe 15mm (cut as needed)	100'
SS Pipe 15mm x 19".....	X3
PE Pipe 15mm x 78"	X3
Straight Connector 15mm.....	X3
Tee Connector 15mm.....	X3
Hardware Package.....	X1

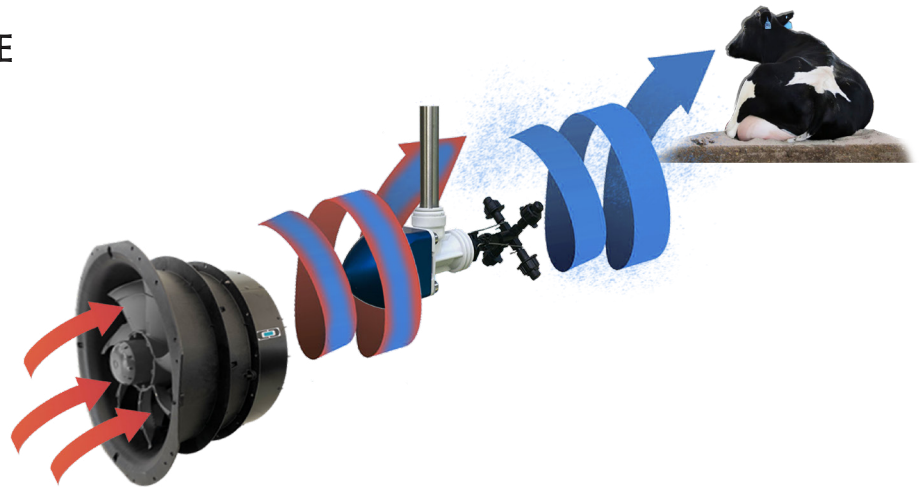

25" CORE COOL SYSTEMS EC SPECIFICATIONS

General

Diameter	25" (63.5 cm)
Number of Blades	7
Maximum Speed	1600 rpm
Operation Ambient Air Temperature	-31°F to 131°F (-35°C to 55°C)
Blades & Rotor	Cast Aluminum Powder Coated Blue
Housing	Polypropylene Black
Weight	77 lbs (35 kgs)

Performance

Area of Coverage.....	8' x 100' (2.4 m x 30 m)
Cows Cooled.....	25
Water Usage*.....	21L per hour

Motor

Type.....	EC Variable Speed
Power.....	5 HP (3.7 kW)
Volt, Phase, Hertz	380 - 480 V, 3~, 50/60 Hz
Amps Consumed.....	3.4 A
Degree of Protection	IP55

*Water usage based on 25% cycle.
These specifications are guidelines only and are subject to change without notice.

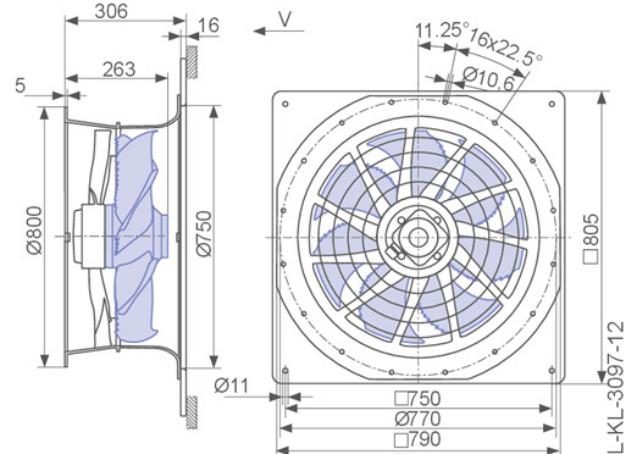

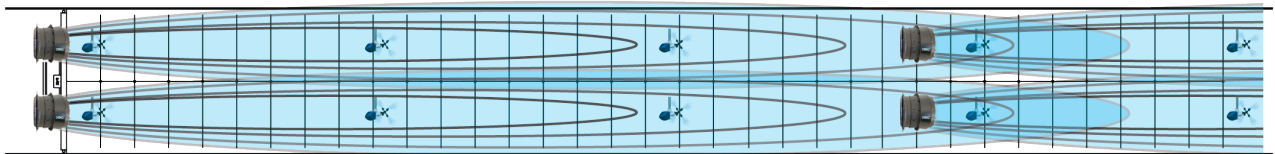
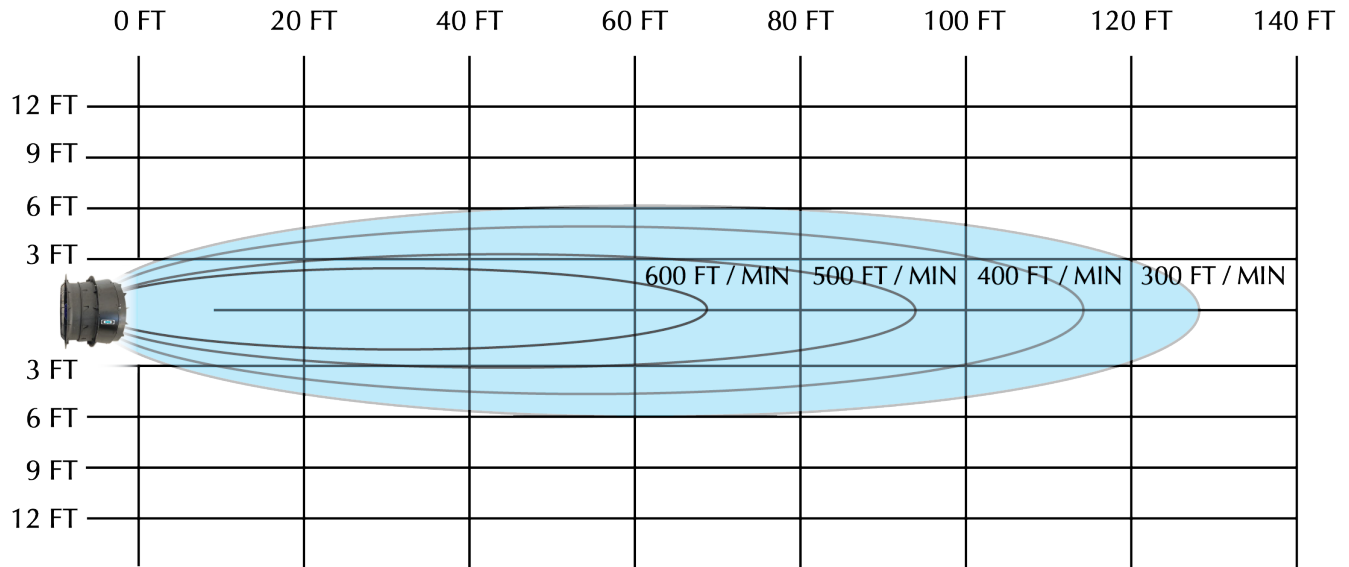

STALL COVERAGE VIEW

