

SUN-NORTH SYSTEMS LTD.

The Natural Ventilation Experts

Nova-Lite Panel
Providing natural light and ventilation.



SUN-NORTH SYSTEMS LTD.

The Natural Ventilation Experts

Nova-Lite Panel *Providing natural light and ventilation.*

Sun-North Systems Ltd. manufactures and installs Nova-Lite sliding polycarbonate or acrylic glass panels in a wide range of sizes. The panels are virtually unbreakable and allow 99% light penetration.

Ask for Nova-Lite with its 1.5R value and all aluminum heavy duty window and perimeter frame assembly. Our clients find it the best panel for their milking parlours and equine areas.

- Continuous sidewall windows made to fit any length.
- 12" to 6' in height.
- Minimum maintenance.
- Stainless steel cable system and pulleys with bearings to ensure long life.

SN027X0024-0272

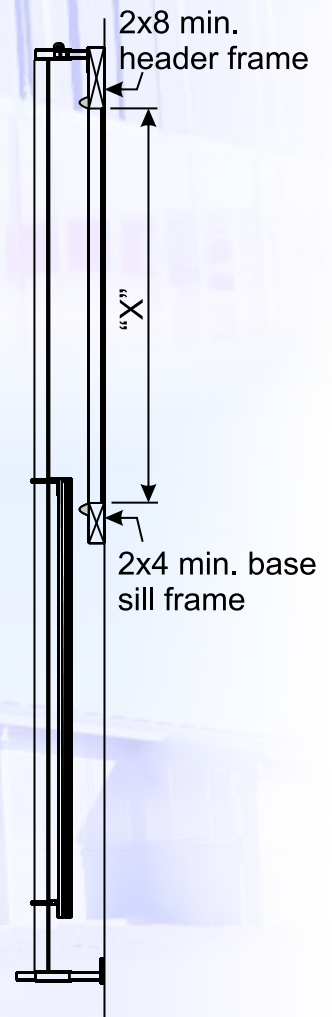
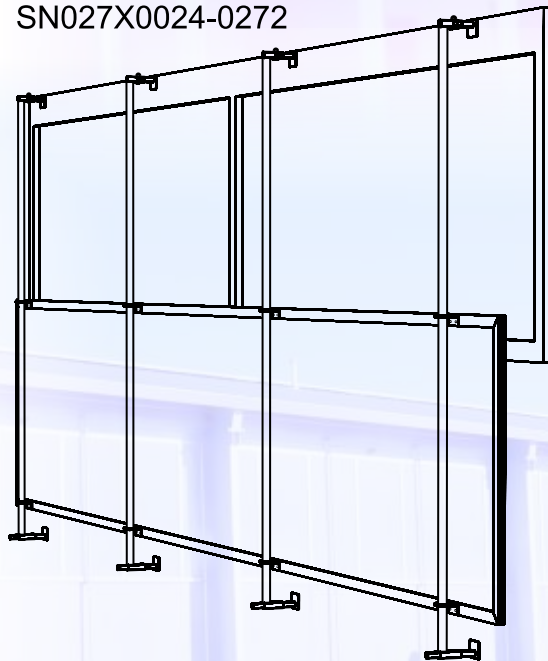

92 Railway St., Box 668
Seaforth, Ontario, Canada N0K 1W0
Tel: (519)527-2470 Fax: (519)527-2560

www.sunnorth.com

Printed in Canada SN900X0103