

# Core Cool

MISTING SYSTEM

## INCLUDED IN CORE COOL PACKAGE

32" Core Cool Fan Assembly EC .....	X1
32" Core Cool Air Shaper.....	X1
Post Mount Bracket for 32" CC.....	X1
Core Cool Quad Tip Nozzle Assembly.....	X6
Ultra Fine Nozzle Tips .....	X48
Block Off Tips (not typically required).....	X2
PE Pipe 15mm (cut as needed) .....	300'
SS Pipe 15mm x 19".....	X6
PE Pipe 15mm x 78" .....	X6
Straight Connector 15mm.....	X6
Tee Connector 15mm.....	X6
Hardware Package.....	X1

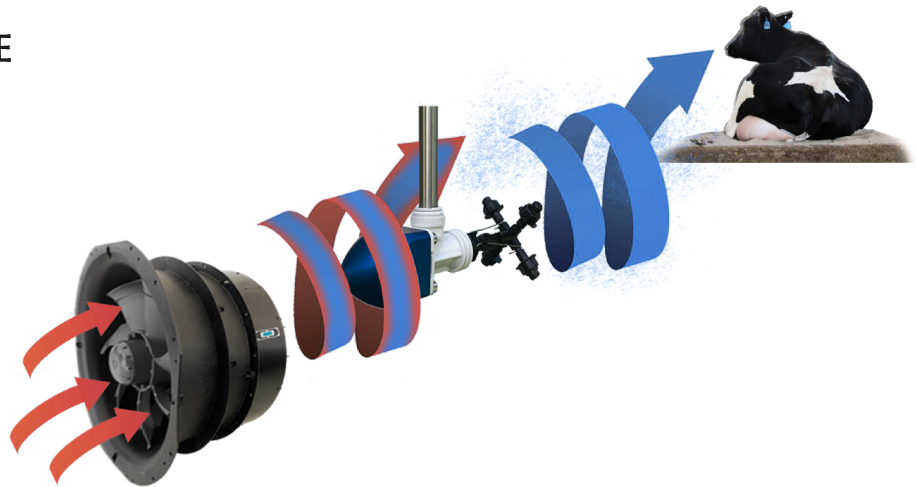

## 32" CORE COOL SYSTEMS AC SPECIFICATIONS

### General

Diameter .....	32" (80 cm)
Number of Blades .....	7
Maximum Speed .....	1250 rpm
Operation Ambient Air Temperature .....	-31°F to 113°F (-35°C to 45°C)
Blades & Rotor .....	Cast Aluminum Powder Coated Blue
Housing .....	Polypropylene Black
Weight .....	132 lbs (60 kgs)

### Performance

Area of Coverage.....	17' x 100' (5.2 m x 30 m)
Number of Cows Cooled.....	50
Water Usage*.....	42L per hour

### Motor

Type.....	EC Variable Speed
Power.....	5.4 HP (4 kW)
Volt, Phase, Hertz .....	380 - 480 V, 3~, 50/60 Hz
Amps Consumed.....	4.5 A
Degree of Protection .....	IP55

\*Water usage based on 25% cycle.  
These specifications are guidelines only and are subject to change without notice.

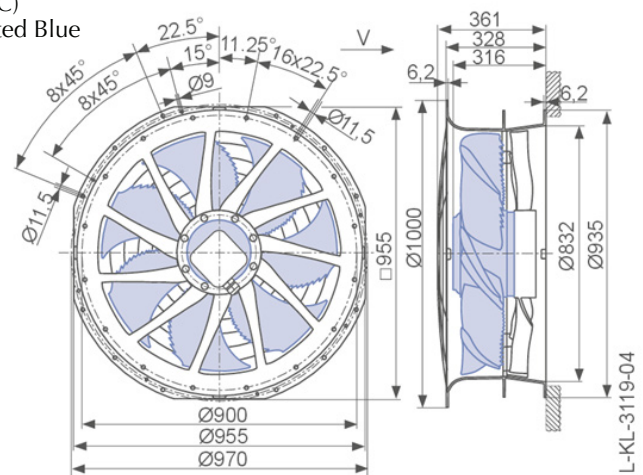

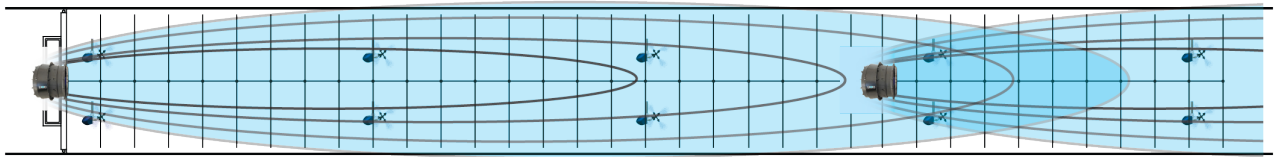
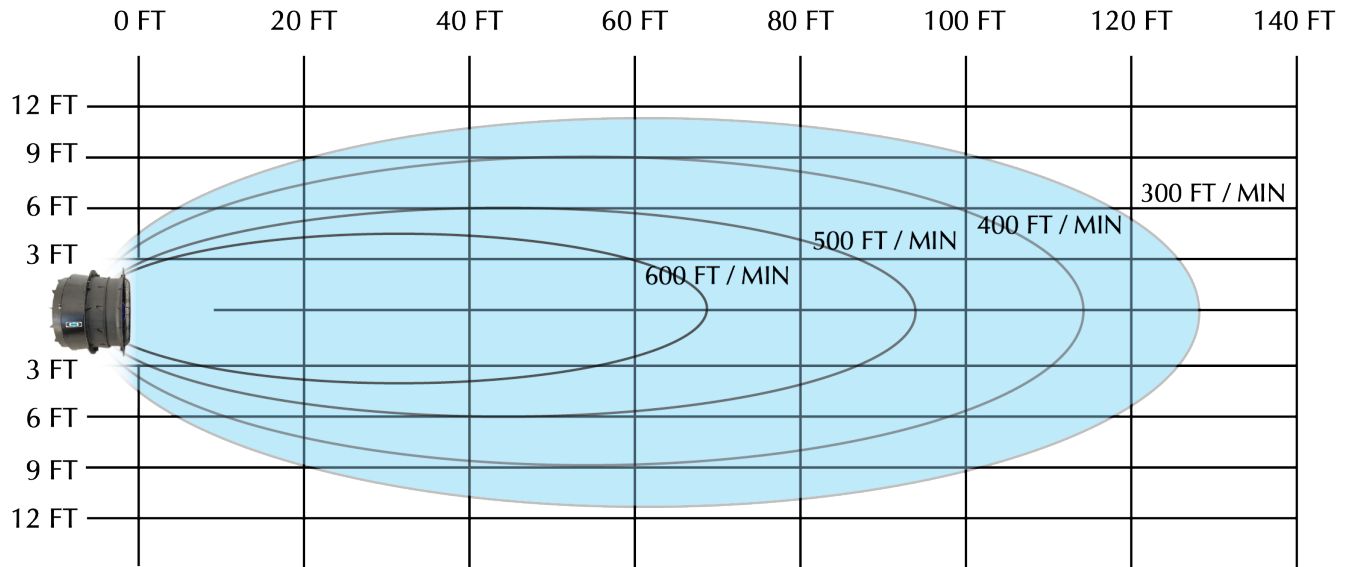

**STALL COVERAGE VIEW**

